



# Schedule T – Navigation Rally Competition

[Click to download PDF](#)

## Appendix Five Navigation Rally Competition

Contents Last Updated: 17 November 2020

### Part One – Foreword

---

Foreword

---

Acknowledgements

---

### Part Two – Introduction to Navigation Rallying

---

Article 1	Abbreviations
Article 2	Definition of a Navigation Rally
Article 3	Entering a Navigation Rally

---

### Part Three – Rules Governing the Actual Event

---

Article 4	Instructions
Article 5	General
Article 6	Checks and Controls
Article 7	Signs
Article 8	Signs Erected by the Organisers
Article 9	Roads
Article 10	Intersections
Article 11	Odo Distance
Article 12	CRI by Measurement
Article 13	Common Route and 'Traps'
Article 14	Timing
Article 15	Tulip Diagrams
Article 16	Straight Line maps
Article 17	Mapreading
Article 18	Delays, Claims, Allowances
Article 19	Complaints, Protests, Appeals
Article 20	Penalties

---

# Part Four – Diagrams

The Diagrams Applicable to Appropriate Rules of this Schedule

## Part Five – Hints

Helpful Hints

**Note:** *Text changes from the previous issue of this Schedule are highlighted such. Text changes for grammatical and/or formatting reasons are not highlighted.*

### Part One – Introduction

#### Foreword:

When the Association of NZ Car Clubs was formed the discipline of Navigation Rallies (formally known as car trials) was a very popular activity in which the majority of club members participated in on a regular basis.

As Motorsport has evolved over the last 60 years Navigation Rallying has remained in very much the same style as it was, however rally activities have tended to overshadow it. Navigation Rallying is a unique sporting discipline which some have called “chess on wheels”.

This publication, prepared by the ClubSport Advisory Commission, contains the rules and regulations, along with Helpful Hints, all aimed at keeping the fun in our sport and seeking the opportunity to introduce more competitors to this type of event.

#### **VALIDITY:**

*The various regulations contained in this Schedule become effective as from the **1<sup>st</sup> January 2019**.  
This publication supersedes all previous editions.*

#### Acknowledgements:

In the production of text for this Schedule MotorSport New Zealand gratefully acknowledges the assistance of all members of the ClubSport Advisory Commission and also Mr John Pierson and Mr Ian McKee, for their countless hours in drafting text, and updated by Ian McKee and Allan Coker.

### Part Two – Introduction to Navigation Rallying

Navigation Rallying (as it is known overseas but was previously called Car Trialling in New Zealand) is the cheapest form of motorsport with competition at a national level. While it is not necessary to compete seriously at the highest level, many car clubs (and quite a few social clubs) run regular Navigation Rallies. These range from social events to equally enjoyable events following all the rules of the national events, but without their length and complexity.

The minimum requirements needed to compete in a Navigation Rally are; a motor vehicle with a speedometer and odometer, a driver, at least one other person, a clipboard and pen, and a reliable watch or clock. You may take as many other passengers as you like, up to the maximum seating limit of your vehicle. The NZ Road rules must be obeyed at all times.

All Navigation Rallies must comply with these regulations. MotorSport NZ Championship Navigation Rallies shall comply with the Articles governing same.

- 1. Abbreviations:** The following abbreviations, in either upper and/or lower case, are used in this Schedule and may be used in Supplementary Regulations, instructions and documentation pertaining to the event:

<b>CAS</b>	Change Average Speed
<b>CM</b>	Centimetres
<b>CRI</b>	Competitors Running Instruction(s)
<b>GR</b>	Grid Reference
<b>JNC</b>	Junction

<b>KM</b>	Kilometre(s)
<b>KPH</b>	Kilometres Per Hour
<b>M</b>	Metre(s)
<b>MotorSport NZ</b>	MotorSport New Zealand Inc
<b>NSC</b>	National Sporting Code
<b>ODO</b>	Odometer
<b>ORS</b>	Open road sign
<b>SR</b>	Supplementary Regulation(s)
<b>NRCB</b>	Navigation Rally Competition Booklet

## 2. Definition of a Navigation Rally:

**2.1** A Navigation Rally is a non-speed competition wherein the main portion of the route is over public highways, roads and streets. It is an event where competitors follow a set of written instructions and the scoring of the competition is for adherence to the correct route maintenance of the prescribed time and/or speed schedule. If competitors make mistakes they will traverse a different course and travel a different distance.

**2.2** Points are lost for arriving late or early at time checks or controls, some known some unknown, and for not recording check codes from check boards erected by the organiser on the correct route. Points may also be lost for not obeying the road code.

**2.3** A Navigation Rally can be seen as a battle of wits between the organiser and the competitors. However the Organisers responsibility is to create a competition between the competing crews, whereby the Organiser tries to trap the competitors into following an incorrect route, while the competitors try to avoid the traps and follow the correct route.

**3. Entering a Navigation Rally:** This part covers the entry requirements, the crew of the car, the eligibility of vehicles, equipment, compliance with traffic regulations, special regulations regarding radio and phone equipment and alcohol and drug regulations.

**3.1** Entries will open and close in accordance with the provisions of the SR and all entries and associated fees (if any), must be lodged direct with the Secretary of the meeting. Late entries may be accepted by an organising committee, and such late entries may be subjected to an additional entry fee, the details of which must be prescribed in the SR.

**3.2** All entries should be made through the MotorSport Online system. An entry will not be deemed valid until an entry fee as prescribed in the SR is received.

**3.2.1** The Organiser is responsible for ensuring that all details are complete before each competitor can start.

**3.3** All vehicle owners, entrants, drivers, co-drivers, passengers and crew members must, prior to participation, sign the indemnity form and other appropriate requirements as set out in the SR. Any signatory to an entry who is under the age of 16 years as at the date of the start of the event is required to have such an entry counter-signed by a parent/guardian whose full name and address must also be given.

**3.4** Subject to the provision of the SR for a Navigation Rally, teams of cars may be accepted for participation in such events.

**3.5** The SR for a Navigation Rally may prescribe that a predetermined number of entries only will be accepted, and in such case, the method to be adopted for the selection of such entries must be stated in the SR. If no such maximum number of entries to be accepted is nominated in the SR, then all entries (subject to the provisions of Article 3.7) received at the closing date for entries will be accepted.

**3.6** All SR governing the event must be available to competitors no later than at Documentation. Copies must be available at Documentation. For MotorSport NZ Championship Navigation Rallies, all SR must be available on request at least 14 days prior to the event.

**3.7** In accordance with the NSC, the Organiser of a Navigation Rally, may decline to accept any particular entry without stating a reason for such declination. However, should such event be one for which Championship status has been granted by MotorSport NZ then any and all declinations of entries must be notified to the entrants concerned and MotorSport NZ concurrently. MotorSport NZ must be advised the reason therefore.

**3.8** In the event of abandonment of the event or any entry being declined by the Organiser, entry fees as paid will be refunded as detailed in the SR.

**3.9** The SR for a Navigation Rally shall prescribe whether Article 16.1 Sealed Timepiece System, or Article 16.2 Official

Timepiece System shall apply.

- 3.10** Organisers responsibilities are contained in the Navigation Rally Organisers Handbook (Chapter 9 of the ClubSport Organisers Handbook).
- 3.11 Crew of the Car:** Unless competing in either their first or second introductory event, every driver and co-driver must be a financial member of a car club affiliated to MotorSport NZ and hold a current civil driver's licence. For MotorSport New Zealand Championship events all such drivers must hold an M Grade Competition Licence, as a minimum grade, as issued by MotorSport NZ.
- 3.11.1** The minimum crew for each vehicle entered in a Navigation Rally will be a driver and one other person. Passengers may be carried up to, but not exceeding, the registered carrying capacity for the vehicle entered.
- 3.11.2** The driver and the co-driver may share the driving and no passengers other than the nominated driver or co-driver may assist with the driving. In events over twelve(12) hours duration for each competitor, one of the crew must be nominated as co-driver.
- 3.11.3** Unless otherwise prescribed in SR any change of driver, co-driver and/or crew and/or passengers from those nominated on the official entry must be made to the secretary of the meeting prior to the start of the event.
- 3.11.4** Every driver and co-driver will be required on request to present to the secretary of the meeting for inspection the following:
- (1) Evidence of current club membership.
  - (2) A current driver's licence for Class 1 Vehicles.
- 3.12 Eligibility of Vehicles:** Navigation Rallies held under these regulations are open to the following types of vehicles; cars, station-wagons, estate cars, SUVs, vans and utilities.
- (1) Every vehicle entered for a Navigation Rally held under these regulations must be registered and currently licensed under the NZ Transport Act 1962 (and amendments thereto) and must carry a Warrant of Fitness valid for the duration of the event.
  - (2) Additional lighting is permitted. The fitting of one manoeuvrable searchlight on the roof or elsewhere is permitted under these regulations. Such a manoeuvrable searchlight must not be used within a 50 kph area.
  - (3) Unless the SR prescribe otherwise, the vehicle nominated on the official entry for a Navigation Rally must be used for the duration of such event; no change of vehicle being permitted.
  - (4) Each vehicle entered for a Navigation Rally held under these regulations will be required to arrive at the start line of such event with any competition number, if required to be carried (provided by the organiser of the event), displayed on the sides of the vehicle, and placed as high as is reasonably practicable. The competition numbers must be waterproof and maintained in legible condition throughout the duration of the event.
- 3.12.1** The responsibility lies solely with the entrant of each vehicle in a Navigation Rally to arrange such comprehensive insurance for their vehicle as may be deemed necessary. The attention of entrants is drawn to the fact that most Comprehensive Insurance Policies provide for a General Extension to include Reliability trials limited to road sections only. No additional premium or excess is payable where the event is conducted under the jurisdiction of MotorSport NZ but arrangements should be made for the Insurers to place the appropriate endorsement on the Policy.
- 3.13 Equipment:**
- (1) Tyre chains may be carried and used at the discretion of the driver without penalty.
  - (2) Any form of average speed calculating device and/or navigational aid is permitted to be used without penalty.
  - (3) Each competing car should carry a simple first aid kit, a reflectorised safety triangle and a fire extinguisher of one(1) kilogram dry chemical type or equivalent.
  - (1) Unless the SR prescribes otherwise the greatest distance between the refuelling points will be 300km. The responsibility for the provision of sufficient fuel and any other supplies considered necessary lies solely with the competitor.
- 3.14 Starting Order and/or Procedure:** Competitors starting order may be determined either by ballot, order of receipt of entries or other methods stated in the SR for a Navigation Rally. If no method is stated in the SR then the order of

starting will be determined by order of entry. No cars in a team may be allowed to draw consecutive numbers.

- 3.14.1** Competitors will start from each starting point at not less than two(2) minute intervals and detailed route instructions will be handed to the competitors not less than one(1) minute prior to departure.
- 3.14.2** No oral briefing is allowed other than in club events.
- 3.15 Compliance with Traffic Regulations:** The Road Code, any local by-laws and all Traffic Regulations, and particularly speed limits, must be rigidly complied with throughout the event. Breaches of any such regulations will be penalised and may lead to exclusion. The competitor must be notified or informed of the observed breach of the regulations at the scene of the offence or as soon as possible thereafter.
- 3.15.1** If the average speed prescribed for any particular section of an event is higher than that permitted by a local or temporary Speed Limit competitors are required to observe and obey such restrictions, and make up any time so lost after passing through such restricted area.
- 3.15.2** If the exhaust system of a competing vehicle is inadequate, damaged or faulty to the extent that it causes excessive noise, the competitor will be invited to make repairs or retire or may be compelled to retire by the organiser or officials of the event.
- 3.15.3** Any form of turning and/or stopping signals recognised by the Traffic Regulations will be permitted during daylight or darkness without penalty.
- 3.15.4** Observation Points may be established by the organisers to determine that all traffic regulations are abided by provided all such observation points remain in operation throughout the whole period that the competition is to pass through the operating area.
- 3.15.5** The type and location of an observation point must be notified to the Steward (if any), of the meeting prior to the event.
- 3.15.6** Where, as a result of the establishment of a speed trap, any competitor in the event who is conclusively proved to have exceeded the legal speed limit applicable to that area, they will suffer a penalty represented by a loss of points as set out in the schedule of penalties hereunder.
- 3.15.7** Any form of reckless or dangerous driving will be penalised.
- 3.16 Special Regulations:** The use of radio transmitting and receiving apparatus, eg. cellphone, for the purpose of obtaining outside assistance during the course of a Navigation Rally held under these regulations, is prohibited.
- Note:** *it is permitted to use any of other non-communication functions available on the cellphone (eg. calculator, timer function etc). Direct communication with the Organiser or their delegated official is permitted.*
- 3.16.1** The consumption of liquor or illegal non-prescription and banned drugs by any occupant of a vehicle competing in a Navigation Rally during the course of such event is strictly prohibited. Any and all offenders will be forthwith excluded from the competition and debarred from further participation in that competition.

## Part Three – Rules Governing the Actual Event

The rules under the next parts cover the types of instructions to competitors, operation of Check and Control points, signs, definitions of roads and intersections, timing, claims, awards and penalties. The diagrams in Part Four are shown as examples only.

- 4. Instructions:** The competitors in a Navigation Rally must comply with instructions from many sources. Depending on the level of the Navigation Rally they may come from any or all of the following:
- The Road Code
  - The current New Zealand MotorSport Manual
  - This Appendix 5 Schedule T, Navigation Rally Competition
  - Navigation Rally Organisers Handbook
  - MotorSport NZ Navigation Rally Championship Articles
  - Supplementary Regulations
  - Bulletins
  - Overriding Instructions
  - Manned Check or Control Handouts

- Competitors Running Instructions

**4.1 The Road Code:** The rules and regulations governing all motorists as issued in the Road Code MUST be obeyed at all times, and breaches may incur penalties.

**4.2 New Zealand MotorSport Manual:** This manual contains the National Sporting Code and is a set of rules applying to all motorsport events in New Zealand run under the jurisdiction of MotorSport NZ. It is issued to all car clubs and all holders of a MotorSport NZ competition licence.

*Note: A MotorSport NZ competition licence is not required for competitors in club Navigation Rallies.*

**4.3 Navigation Rally Competition Booklet:** This booklet is Appendix 5 Schedule T, and covers the Rules and Regulations to be obeyed by competitors.

**4.4 Navigation Rally Organisers Handbook:** This is Chapter 9 of the ClubSport Organisers Handbook, and covers the requirements applicable to Organisers.

**4.5 The Articles Governing MotorSport NZ Navigation Rally Championship:** Additional rules and regulations applicable only to MotorSport NZ Championship events.

**4.6 Supplementary Regulations:** These are issued by the Organiser of a Navigation Rally. They give information regarding the conduct of the event in addition to, or in explanation of, the requirements of the New Zealand Motorsport Manual, the requirements of the Navigation Rally Organisers Handbook and in particular the rules in Appendix 5, Schedule T.

For club Navigation Rallies the SR are available from the organiser at documentation for the event. For national events the SR are available two(2) weeks prior to the event.

**4.7 Bulletins:** These are used to make alterations or additions to the SR.

**4.8 Overriding Instructions:** If overriding instructions, additional to the SR, are to be used these must be limited to one(1) only in any one(1) section or subsection.

(1) Overriding instructions in the SR are to apply to all sections and subsections of the event except map reading sections or subsections. This rule is in no way to prejudice Articles 8.2 or 10.2, or the use of coded check boards.

(2) Overriding instructions in the CRI apply only for the section or subsection that the CRI apply to and are always listed above the CRI. They may also be limited to apply only between specified CRI. (eg: Applies only from CRI 7 to 28 inclusive).

Check their order of priority in the SR, this will determine when they are to be actioned.

**4.9 Manned Check or Control Handouts:**

(1) **Manned Checks** are vehicles located on the route by the organiser to check the timing and/or progress of competitors. They are identified by a sign "CHECK" (and no identifying letter(s)) on the back of the vehicle. It is compulsory to stop, in front of the manned Check vehicle (legally) so as not to block the visibility of the sign, and report to the person inside. The person at the Manned Check may issue a written handout. This is a list of written instructions that apply in the priority specified in the SR.

(2) **Controls** are similar to Manned Checks, except that the sign on the rear of the vehicle, or entry of the property/building, is "CONTROL", and they signify the end of a section of a Navigation Rally. The person at the Control may also issue a written handout which must be followed in the priority specified in the SR. A "CONTROL" may also be at the start of an event or any subsequent re start such as after a lunch break.

**4.10 Competitor's Running Instructions (CRI):** CRI are the basic instructions which advise how to negotiate most intersections. But remember to apply other instructions in the SR priority list as applicable.

**Helpful hint:** *Tick off each instruction as it is completed and cross out each instruction that is deleted.*

**4.10.1** A copy of all CRI will be provided for each crew member other than the driver in each competing vehicle following the correct route.

**4.10.2** The event may be divided into sections and may be further divided into subsections.

- 4.10.3** The maximum time for any one(1) section shall be three(3) hours and provisions for compulsory rest stops of a minimum of thirty(30) minutes shall be made at intervals not exceeding four(4) hours throughout all Navigation Rallies.
- 4.10.4** The route within an area with a speed limit of less than 61kph must not involve intricate route finding or any unnecessary deviations from the most direct or reasonable course, except in Social events of less than 100km, and then only at the Permit Issuing Authority's discretion.
- 4.10.5** The CRI shall include clearly stated points at which changes of speed and/or directions are prescribed.
- 4.10.6** All CRI must be in the order the competitor is to use them. This includes average speed changes and organisers' additional instructions given or obtained at Checks or Controls throughout the event. Speed changes may be a separate listing. There shall be only one(1) navigational and/or timekeeping instruction at any one(1) route point at any one time. If a timekeeping instruction is given at the same route point as a navigational instruction then it must be combined with the navigational instruction or listed in a separate Speed Schedule.
- 4.10.7** All average speeds shall be in kilometres per hour only.
- 4.10.8** The CRI as issued for a Navigation Rally must be followed implicitly as failure to pass through Checks and/or Controls as directed and in the correct order of designation will incur a penalty under Article 20.12 or 20.17 as appropriate.

## **5. General:**

- 5.1 Driver's Card:** This is a card (or sheet of paper) issued by the Organiser to each crew so that they can record the code letters (or numbers or words) on each unmanned check in the order they are found. This card and a time-piece must also be given to each Manned Check or Control where time will be recorded in the next blank space, EXCEPT some manned checks may only sign the card and may issue a Handout.

## **6. Checks and Controls:**

- 6.1** Except in touring sections/sub-sections, Checks and/or Controls shall be established at intervals to ensure that a competitor following the official or common route does not travel more than six(6) kilometres at any one time without encountering a Check or Control. The six(6) kilometre limit need not apply **before the ODO or** from the final check to final control where the control is within a city and provided:

- (1)** That the final check is close to city limits and/or a common route.
- (2)** That the final check is identifiable by the Code F prescribed in the SR and is non-directional and carries no other meaning.
- (3)** That the route from final check to final control be kept as simple as possible.

- 6.2** Controls shall be located and deemed to be at the end of each section. At each Control any uncompleted instructions for that section shall be deleted.

- 6.3** Checks and Controls shall be located in such position that their establishment will not obstruct or cause any hazard to other road users, or cause any annoyance to nearby residents (for any reason whatsoever) or be sited contrary to traffic regulations or any local by-laws. In all cases they shall be located on the left hand side of the road as viewed by the approaching competitors traversing the correct route. The vehicles used by all Checks and Controls in the hours of darkness shall have side lights on for the duration of their duties.

- 6.4** The purpose of Checks and Controls will be to establish any one or more of the following:

- (1)** The passage of competitors' vehicles past that point.
- (2)** The time of the passage of a competitors' vehicle past that point for the purpose of establishing maintenance of the prescribed time and/or average speed schedule.
- (3)** Compliance with traffic regulations in respect of driving and/or controlling of the vehicle or speed limits.

- 6.5 Organisers Responsibility:** In the event of a Check or Control due to be manned by officials not in fact being manned during the whole period when the competitors may report then all performances at such a point will be ignored in compiling the results.

- 6.6** All checks where time is recorded must be on the common route. A time check will have the word TIME on the board in addition to the word CHECK. A further letter may be used for Time Check identification. These may be manned or unmanned.

- 6.7** Where a competitor incurs time penalty points lost due to incorrect arrival at a Check or Control will be recorded against such competitor as irrevocably lost at that point.
- 6.8** All Checks and Controls must remain open for a minimum of sixty(60) minutes after the official scheduled time of arrival of the last competitor in the event, unless all competitors have passed through that point, whereupon such Check or Control may be closed. Competitors arriving later than thirty(30) minutes after their official scheduled time of arrival at a Control may be excluded from the results of the next section and be sent to the start of the following section.
- 6.9** The exact location of all Controls and end of subsection Checks must be clearly specified in the CRI.
- 6.10** At all manned Checks and Controls, unless directed in the CRI to do otherwise, each competitor shall:
- (1)** Stop past the Check or Control (so as not to obscure the Check or Control sign), park in accordance with the traffic regulations and any local by-laws before any occupant leaves the vehicle to,
  - (2)** Report to the officials in charge of the Check or Control and produce the driver's card or other identification and any other requirements as laid down in the SR to the officials for appropriate entry as to the time of arrival (or other entry as may be required). All entries made on the driver's card and other records must be signed by the official in charge and countersigned by the driver concerned or his representative. Any deletion, alteration or correction to the recorded time must be made at the point and signed by the official (*Refer Article 20.21 for penalty*). On the vehicle leaving the Check or Control, the time so recorded is irrevocable.
  - (3)** Carry out any further instructions as may be given verbally by the official in charge at that point. Such verbal instruction must not refer to a variation of the course to be followed, or the average speed to be maintained.
- 6.11** An unmanned Check may be established on the route provided that the Check sign is on the left-hand side of the road and is clearly visible, and instructions are clear in the SR to the procedure to be adopted at same. No unmanned Check may be placed in a position where it is illegal or dangerous to stop, or where it is likely to be obscured.
- 6.12** All manned Checks and Controls must be identified by a sign bearing only the word CHECK or CONTROL respectively. Unmanned Checks must be identified by a sign bearing the word CHECK plus additional character(s).
- 6.13** Unless a longer period is specified in the SR or CRI an allowance of one(1) minute must be given at all manned Checks and an allowance of two(2) minutes must be given at all Controls. A competitor must add this time allowance to his running time after checking in at all Checks and Controls. The start of the event, or any subsequent restart after a break, does not constitute a Control in so far as this time allowance is concerned.
- 6.14** Unauthorised stopping or deliberate deviation from the official course, designed to delay the arrival time at manned Checks and/or Controls, executed within sight of such points, will be penalised under Article 20.13.
- 6.15** Inconsiderate driving and/or misbehaviour entering or leaving Checks or Controls etc., by competitors, will be reported and incur penalties according to Article 20.2.

## **7. Signs:**

- 7.1** In any instruction any and all references to signs, notices and/or landmarks must contain the exact words, letters and/or numbers as stated on such signs, or notice or description of such landmarks, and all words, letters and/or numbers must be clearly visible from the competitor's car along the correct line of approach.

The method by which letters and numbers on signs are quoted will be stated in the SR. For directional purposes, only one sign is to be quoted at any one route point at any one time.

The following shall play no part in the identification of quoted signs:

- (1)** Punctuation and arrows.
- (2)** AA insignia, initials and emblems.
- (3)** Local body, NZTA, car club names, initials, insignia and emblems.
- (4)** Road markings, street and house numbers.
- (5)** Postal Zones and Codes.
- (6)** Highway shields and numbers.



In the quotation of signs, any and all spaces between the numbers and the letters "km" or "m" of a quoted distance are deemed not to exist. The following examples define the difference between one and two signs:

(a) Two(2) signs in each case: (*Refer diagrams D1, D2, D3, D4*)

(b) One(1) sign in each case: (*Refer diagrams D5, D6*)

- 7.2 Signposts and/or notice boards erected by an Automobile Association, NZTA, Local Body or Government Authority may be used but must not be interfered with or altered in any way whatsoever.
- 7.3 All detour signs erected by a Local Body, Automobile Association, NZTA, Government or other Authority must be obeyed by all competitors in a Navigation Rally.
- 7.4 References to letterboxes and house numbers must not be used in the CRI.
- 7.5 To follow a sign means to proceed along the road that is indicated by the said sign.
- 7.6 All no entry signs erected by a Local Body, Automobile Association, NZTA, Governmental or other Authority are to be interpreted as obviously intended.
- 7.7 Signs which pertain to, or are accessories to intersections are deemed to be at such intersections.
- 7.8 The sign (*refer diagram D7*) is defined as an Open Road sign and may be quoted as such in the CRI and SR without prejudicing any requirements that signs will be quoted word and letter perfect.

## 8. Signs Erected by Organisers:

- 8.1 **Checks and Controls:** All manned Checks and Controls must be identified by a sign bearing only the word CHECK or CONTROL respectively, and unmanned Checks must be identified by a sign bearing the word CHECK plus at least one additional character. These signs must be a minimum of 45cm wide by 30cm high painted black with white lettering. The minimum height of the letters in the word CHECK or CONTROL is ten(10) cm. For unmanned Time Checks the word TIME must be a minimum height of five(5) cm. (*Refer diagrams D10, D11, D12*).

All code characters must be permanently affixed. All code characters must be of a minimum height of five(5) cm.

- 8.2 **Arrows:** Travel in the direction indicated by the arrows.

(1) A plain arrow is an additional instruction. (*Refer diagram D8*).

(2) An arrow with a "C" or a reversed "C" superimposed is a clarification arrow to clarify a CRI. The CRI is then deemed completed. (*Refer diagram D9*).

- The arrow signs must be a minimum of 45cm wide by 15cm high, painted black with a white arrow the full length of the board.
- No arrows may be erected which are parallel to the competitor's direction of travel. An arrow erected in a vertical position with the arrowhead pointing upwards as viewed by the approaching competitor signifies the use of the road of least deviation. An arrow erected in a vertical position with the arrowhead pointing downwards as viewed by the approaching competitor signifies a U turn is necessary.
- All signs as per 8.1 and 8.2 must be located on the official route.

- 8.3 **No road board:** (*refer diagram D13*) The sign must be a minimum of 45cm wide by 30cm high, painted black and the "X" painted in white. The "X" must reach each corner of the board. Such a sign makes a road non-existent.

- 8.4 All Check, Control and unmanned Check signs, arrows and signs to clarify private roads used in the hours of darkness must bear at least 25 square centimetres of reflectorised tape. The reflectorised tape must be placed near the border of the sign, and must not form part of the wording of the sign.

- 8.5 All unmanned signs erected by the organiser must be wholly sited a minimum of 0.5m and a maximum of 2m from the level of the road clearly visible from the direction of approach (*viz.* unmanned checks, arrows, etc.). Organisers cannot erect unmanned checks before the ODO and, where possible, signs are to be sited within 2.5m of the road edge.

- 8.6 A special sign or notice or extra instruction may be erected by the organiser of the event provided that a specimen of the type of sign has been displayed to all competitors prior to the start of the event. The minimum size of any such sign must be 45cm wide by 15cm high. Often referred to as a "Blackboard Instruction" this board may be headed with "BB INSTRUCTION", "ADD INSTRUCTION", "INSTRUCTION", "BLACKBOARD INSTRUCTION" or "ADDITIONAL INSTRUCTION".
- 8.7 A specimen of all Check, Control, unmanned Check, and no road boards, arrows and clarification arrows as may be used on the event must be displayed to all competitors at pre-event documentation.
- 8.8 **Additional signs for clarification of CRI quoting signs:** When it is necessary to clarify a CRI without using a directional arrow, the following signs will be used. They shall have the same purpose, excepting the directional requirements, as a clarification arrow. The sign must be a minimum of 30cm wide by 30cm high and painted in white against a black background.
- (1) Sign to clarify a speed change CRI: A large 'S'. (*Refer diagram D14*)
  - (2) Sign to clarify a navigational CRI: A large 'N'. (*Refer diagram D15*)
9. **Roads:**
- 9.1 All Navigation Rallies must be conducted over roads which are negotiable on the day of the event by two-wheel drive vehicles.
- 9.2 Where adverse weather conditions (e.g. flooding streams, snow, mud or slips resulting from force majeure) may prevent the negotiation of any section of the route, alternative routes must be prepared and submitted with the original application for permit.
- 9.3 **Private Road:** No private road will be used for the route of a Navigation Rally except where the person or body owning and/or controlling such road has granted prior approval to the promoter of the event for such use. This must be in writing and attached to the application for permit. The SR for an event must state how the organiser interprets the identification of a private road. Where doubt exists a No Road board may be erected at the start of such road.
- 9.4 A road is defined as a motorway, national state highway, provincial state highway, street, road, avenue, crescent, place, drive, parade and any other way to which the public have access as of right, and which is normally or can reasonably be used by an automobile.
10. **Intersections:**
- 10.1 An intersection is defined as the junction of three or more roads. ie. The minimum requirement is as per diagram D19. An intersection encompassing an area of a different surface from that of the road, provided that all entries and exits of the encompassing road are visible from the point of arrival, is deemed to be one intersection.
- 10.2 The SR must prescribe the rule to be used to negotiate each intersection until the appropriate instruction can be executed. These rules include:
- (1) **Straight Ahead Rule:** Proceed ahead on the road of least deviation even though this may require departure from the road on which the competitor is travelling.
  - (2) **Main Road Rule:** defined as to proceed on the most obvious continuation of the road you are on. This rule may also be used as an individual instruction in the CRI provided the words "apply main road rule" are included in the CRI.
- 10.3 Except as in Article 15 or Article 16 no instructions which depend on specific angles may be used to describe direction changes.
- 10.4 The SR and CRI may use the following definitions to describe intersections:
- (1) A **tee** is defined as an intersection in the shape of a "T" provided that the competitor has been travelling up the road forming the vertical leg of the "T". (*Refer diagrams D16, D17, D18*)
  - (2) A **crossroads** is defined as an intersection of four(4) roads. (*Refer diagrams D20, D21*)
  - (3) A **multiple** is defined as an intersection of more than four(4) roads. (*Refer diagram D22*)
  - (4) A **roundabout** is defined as an intersection encompassing an area around which traffic is only permitted to travel in a clockwise direction. A roundabout cannot be a crossroads, a multiple, or a tee. Instructions must indicate

which exit or road on the left must be used to leave a roundabout. This instruction may be in in the CRI or in the SR. (Refer diagram D23)

- (5) An **imperfect** is defined as being an intersection where the road to be followed is offset (either to the right or to the left) from the road on which the competitor has been travelling by not more than the width of the road on which the competitor has been travelling, but CRI must include definite instructions so as to be able to negotiate an imperfect intersection. (Refer diagrams D24, D25, D26)

## 10.5 Other Definitions:

### 10.5.1 Road with Median Strip:

- (1) When passing the entrance of a road to which direct entry is not possible it is not permissible to consider that road in any navigation or timekeeping instruction. The road does not exist. (Refer diagram D27)
- (2) Where local Traffic Regulations permit the passage of wheeled traffic in two(2) directions on each of two parallel or approximately parallel carriageways divided by a median strip (whether sealed, cultivated, grass, with or without a kerb surround, or merely painted on the road surface) and such carriageways are designated by one or different names, then these carriageways shall be regarded as two(2) roads. (Refer diagram D28)
- (3) Where local Traffic Regulations permit the passage of wheeled traffic in one(1) direction only on each of two(2) parallel or approximately parallel carriageways divided by a median strip (whether sealed, cultivated, grass, with or without a kerb surround or merely painted on the road surface) and both of such carriageways are designated by one(1) name, then both of such carriageways shall be regarded as one(1) road. (Refer diagram D29).

### 10.5.2 One-way Road: (Refer diagram D30).

- **Prohibited Entrances:** Where entry to a road is prohibited by local traffic regulations (e.g. No Right Turn, No Left Turn, No Entry, Road Closed, lane markings/arrows on road etc.) then such entrance is deemed to be non-existent.

**10.5.3 Straight Ahead:** Proceed ahead on the road of least deviation even though this may require departure from the road on which the competitor is travelling. (Refer diagrams D31, D32).

**10.5.4 Main Road:** Proceed on the most obvious continuation of the road on which the competitor is travelling, usually following the painted centre line road markings (Refer diagrams D31, D32).

**11. Odo Distance:** Navigation Rallies have a known route and distance. Organisers set average speeds, therefore there is a calculated time for travelling the correct route. At an early point in the Navigation Rally the organiser will give a specific route point and the exact distance, as measured by their odometer, from the start of the Navigation Rally.

## 12. CRI by Measurement:

**12.1** An instruction may be given at a specific point determinable by odometer reading providing the distance does not exceed twelve(12) kilometres from a previous point in the event (e.g. Change Average Speed at 7.5km from the start of this section. Turn left 5km from last directional instruction).

- Any CRI involving measurement in change of direction must state "Note odo reading" in the CRI from which the measurement starts.

**12.2** Where a competitor is required to change direction on measurement, no other road may be within 0.3km before the road intended to be used.

## 13. Common Route and Traps:

**13.1 Common Route:** The 'common route' in Navigation Rally language is the roads which are travelled by all competitors. It does not include roads which may be used by competitors who do not recognise a 'trap', or the roads used by those who do recognise a 'trap'.

**13.2 Official Route:** The "official route" in Navigation Rally language is the roads which are travelled by competitors who complete all CRI in a Navigation Rally and who recognise all "traps" set by the organisers.

**13.3 Off Course Route:** (also known as "**Mugs Route**"): The "off course route" in Navigation Rally language is the roads which are travelled by competitors who miss "traps" set by the organisers. They may miss one or two so only go "off course" for a short distance.

**13.4 Traps:** A 'trap' is Navigation Rally language for a situation where the organiser is attempting to have a competitor travel on other than the official route. Examples of 'traps' are listed in Part Five, Helpful Hints.

**14. Timing:** The timing of the competitors' vehicles in a Navigation Rally for the purpose of determination of adherence to the prescribed average speed and/or timing schedule shall be achieved by one of the following methods:

**14.1 Sealed Timepiece System:** The competitor must provide Articles 14.1.1 and 14.1.2.

**14.1.1**

(1) A reliable timepiece accurate to within five(5) minutes in 24 hours, indicating individual hours, minutes and seconds and having a 12 hour reading only and a dial of not less than 3.50cm in diameter with seconds indicated by a full face sweep second hand, or a clock having a digital read out with individual second, minute and hour digits. Prior to the start of the Navigation Rally such timepiece must be submitted to and approved by the organiser. The organiser has the power to impound any clock for a technical inspection by a qualified horologist. The clock must have numbers on its face, including the hour 12.

(2) For Championship status events a reliable timepiece accurate to within one(1) minute in 24 hours and having a digital readout, with individual hour, minute and second digits, at least five(5) millimetres high, displayed simultaneously. The digits should be on one(1) line and in the conventional order of hours, minutes and seconds and shall be either 12 or 24 hour readout. The organiser has the right to impound the timepiece to check its accuracy.

**14.1.2** A container capable of completely housing the timepiece and such container to be fitted with a glass or clear plastic top, and fitted with a means of effectively sealing the container in a closed position by means of:

(1) Wire and lead seals (provided by the organiser), or

(2) Adhesive or self-adhesive non-reusable tape of a type approved by MotorSport NZ (provided and fitted by the organiser).

**14.1.3** The competitor is responsible for setting his clock to the correct time before clock sealing.

**14.1.4 System of Operation:** At each manned Check and Control competitors must stop in accordance with Article 6.10.

(1) The arrival of that competitor is determined as the moment when the competitor hands his sealed timepiece and driver's card to the official.

(2) Competitors, upon handing their sealed timepiece and driver's card to the official shall state the time showing on their sealed timepiece. The official shall then verify the time and provided it is within five(5) seconds either way shall record it.

(3) Both the official and the driver (or crew member) must sign the appropriate entry.

(4) On the vehicle leaving the Check or Control the time so lodged must be accepted by the competitor excepting where, on reference to the preceding and succeeding checks time, the hour hand of the competitor's clock is found to have been mis-read, the organiser must correct this accordingly.

(5) At the organiser's discretion, the competitor's timepiece may be reset and the timepiece resealed in the container. The timepiece must be re-set to five(5) minutes before the competitor is to leave. At all locations where the competitor's timepiece is reset and resealed, a stop of not less than five(5) minutes will be provided solely for this purpose. The competitor shall be given a new time out if his timepiece is reset.

(6) The responsibility for the maintenance of the competitor's sealed timepiece in correct working order lies solely with the competitor. Officials will not be held responsible for the winding and/or adjustment of a competitor's timepiece.

(7) Competitors shall be ready to report to the official within thirty(30) seconds of stopping past the manned Check or Control, failing which they may be liable to penalty.

**14.2 Official Timepiece System:** The organiser must provide the timepieces to be used for the timing of competitors' vehicles in the event. The official time must be displayed at the start of the event. The timepieces used must be accurate to within five(5) minutes in 24 hours. Competitors must report to the official within thirty(30) seconds of stopping past the Manned Check or Control, failing which they may be liable to penalty.

**14.3** Whichever system of timing is employed, competitors will be penalised for early or late arrival at Checks and/or Controls

in accordance with the Schedule of penalties listed herein.

- 14.4 If the SR state that ten(10) second timing will be in operation, official time will be rounded up to the next 10 second increment and clocks will be read to this accuracy only.
- 14.5 Unless a longer period is specified in the SR or CRI, an allowance of one(1) minute must be given for each U turn on the official route.
- 14.6 Whichever system of timing is employed, at each unmanned Time Check competitors must record their arrival time, and identification letter if applicable, at that route point, on the driver's card provided by the organiser. Competitors must sign all such recorded times prior to stopping at the next manned Check or Control.
- 14.7 **Touring Sections:** A Navigation Rally may, by notification in the CRI, include certain sections and/or sub-sections wherein no intermediate checks shall be established. Competitors at the finish of such sections/sub-sections may arrive early but are required to check in at the correct time.

**15. Tulip Diagrams:**

- 15.1 Instructions showing the direction to be followed at intersections by diagrams clearly showing the position of the competitor's arrival at the intersection by means of a dot and an arrow showing the direction to be followed when leaving the intersection. (*Refer diagrams D33, D34*)
- 15.2 At least at every fifth instruction a road sign or other easily identifiable landmark must be quoted or indicated.

**16. Straight Line Maps:**

- 16.1 A straight line map is a diagrammatic representation of the route to be followed by a competitor with the route shown as a straight line. All intersections must be shown. Such intersections must be shown on the side of the road on which they are to be passed by the competitor. The map bears no relationship to the actual angles of intersections of roads nor the actual relative distance between roads.

In order to follow a straight line map the competitor shall interpret a road shown on the left/right of the straight line as meaning he shall leave a road on the left/right. (*Example: Refer diagram D35*)

- 16.2 At least at every fifth intersection a road sign or other easily identifiable landmark must be quoted or indicated.

**17. Map Reading:**

- 17.1 CRI may contain instructions to be read from a map(s) provided that the map to which such instructions apply has been nominated in the SR as follows:

- (1) Only Department of Survey and Land Information TOPO50 maps may be used.
- (2) The name of the map.
- (3) The serial number of the map.
- (4) The date of issue or other information to positively identify such map.

- 17.2 At the beginning of all sections and/or subsections a grid reference and a direction in which the competitor is facing must be specified.

- 17.3 No U-turns are permitted in map reading sections unless specifically instructed.

- 17.4 Map reading instructions must be confined to the following types of instruction or a combination thereof:

- (1) **Instructions involving six(6) figure numerical grid references:** But a direction of arrival and/or departure may be specified. A reference point shall be deemed to be in the centre of the road or intersection and must be plotted as near as possible to the centre of that road or intersection. A grid reference is two(2) three(3) digit numbers expressing latitude (first) and longitude. They will appear in the CRI or SR preceded by GR (or gr). A grid reference referring to an intersection shall carry the suffix JNC (or jnc). All grid references not intended to refer to an intersection must be a minimum of 200m from the centre of any intersection.

- (2) **Named Roads:** A named road means that portion actually named on the map to the nearest side of the next intersection on either end of the name except that named no exit roads are exempt from the proviso of an intersection at the blind end. Where the end of a named road is in doubt the name must be wholly included between perpendiculars to the named road drawn from the ends of that named road (see diagram). Where a portion of a road has two(2) names which apply to it under this definition, then that portion of road can be called by one(1) name only, within any one(1) instruction. Road names are not divisible (e.g. John Smith Road cannot be called Smith Road). (*Refer diagrams D36, D37*).

State Highway numbers are not to be used as names of roads. Instructions quoting named roads must be confined to the following:

- (a) Use a named road.
- (b) Do not use a named road.
- (c) Pass a named road.
- (d) Do not pass a named road.

In all cases the named road shall be the nearest road so named – distance measured by road as per map from the point of commencing the CRI. (*Refer diagram D38*)

**“Use a named road”** means use all the named part in its entirety without deviation from the said road. A direction of travel may be specified.

**Example:** (*Refer diagrams D39, D40*) Use Bell Road.

**“Do not use a named road”** means do not use any or all of the named part of the said road.

**“Pass a named road”** means use an intersection to which the said road is joined but does not cross and without using any or all of the said road or crossing the said road within that instruction. (*Refer diagram D41*)

**“Do not pass a named road”** means do not use any intersection to which an end of the said road is joined and without using any of the said road or crossing the said road within that instruction.

State highway shields, topographical information, descriptive notes are not deemed to make a road impassable.

- (3) It is permissible to specify a type of bridge or ford. Instructions quoting a bridge and/or ford must be confined to the following:

- (a) Cross a bridge.
- (b) Do not cross a bridge.
- (c) Pass through a ford.
- (d) Do not pass through a ford.

If specifying the type of bridge, the specification shall be in accordance with those shown on the Map index. In each case, more than one bridge or ford can be specified. The number of bridges and/or fords quoted in an instruction shall be the minimum number required to execute that instruction.

- (4) U-turn.

**17.5** After satisfying all other map reading requirements, the shortest route to complete each instruction shall apply.

**17.6** Where there is a choice of routes involving measurement to determine the shortest route then such difference in measurement must not be less than 0.5km.

**17.6.1** A loop is where a competitor leaves a point and comes back to that point within one CRI. Where it is possible to traverse the loop in either direction, the organiser must state how to traverse the loop, ie. clockwise or anti-clockwise.

**17.7** Unless otherwise stated in the SR of the event, it is not permissible to use, or plot into, a blind road. A blind road is defined as a road which has no exit.

**17.8** The reference table contained on the map is intended as a guide, and the diagrams shown in it are examples only.

**18. Delays, Claims and Allowances:**

**18.1** If delayed by circumstances beyond the control of a competitor in a Navigation Rally, such competitor will not make up time so lost but will run late until the next time Check or Control and report to the official in charge of the next control point the reason for and the actual delay involved. At the discretion of the organiser of the Navigation Rally, such delays shall not be penalised. If the organiser does not allow the claim, he must notify the said competitor so he can put in a protest within the prescribed time.

**18.2** Except in club events, any claims concerning irregularities in the CRI must be made in writing to the Clerk of the Course within one(1) hour of the competitor finishing the event or the route and speed schedules being displayed. In club events the time limit for lodging claims concerning irregularities in the CRI shall be thirty(30) minutes. All other claims must be handed in immediately on clocking in at Final Control, having been attested to by officials encountered along the route. The organisers must adjudicate on each claim and advise the result to the competitor within one(1) hour of receipt of the claim unless the Steward(s) of the Meeting (if any) allow an extension of time due to the number of claims to be processed.

**18.2.1** A protest against a mistake or irregularity in a Navigation Rally shall be lodged within one(1) hour of the finish of the event for that competitor, or within one(1) hour of refusal of his claim as in Article 18.2.

**18.3** No claims will be allowed for mechanical failures in Navigation Rallies. In the case of an accident involving injury or death, a competitor must stop and render all possible aid. Time so lost will entail a penalty not greater than the least loss by any other competitor in the sections involved.

**18.4** Delays of the type mentioned in Articles 18.1 and 18.3 above must be substantiated by a disinterested party, e.g., by a marshal, an official or a competitor other than in the car concerned.

**18.5** If delayed by tyre failure or broken windscreen, a competitor will be permitted an allowance of up to five(5) minutes without penalty provided that evidence of such tyre failure or breakage is produced to the official in charge at the next manned Check or Control where competitors are required to stop.

**18.6** Except as provided in Article 18.3 above, the maximum delay permitted under the foregoing clauses is thirty(30) minutes and the delays in excess of thirty(30) minutes will involve the penalty of maximum loss of points for that section of a Navigation Rally.

**18.7** The promoters, through their organising committee, shall have the right to reduce the number of penalty points, or to delete all the penalty points applicable to any one or more parts of a section of a Navigation Rally, should road conditions or other circumstances seriously delay the majority of the competitors, subject to the approval of the Steward(s), if any, of the meeting, prior to the publication of provisional results.

**19. Complaints, Protests and Appeals:**

**19.1** **Complaints:** The requirements of organisers re signs and measurements stipulated in this Schedule must be adhered to. However, discrepancies in these areas may be subject of complaint by the Competitor to the Steward of the meeting or if a Steward is not appointed then to the Area Steward for investigation. If the discrepancy in the Investigator's opinion is minimal then the Organiser should be reminded of his obligations. Serious errors may involve penalty on the organiser and may be the subject of protest.

**19.2** **Protests and Appeals:** (*Refer to the National Sporting Code*).

**19.2.1** Should any protest or appeal re an irregularity in route instructions be upheld the points lost by all competitors at that Check(s)/Control(s) shall be deleted.

**20. Penalties:**

**20.1** Breaches of the Traffic Regulations involving excessive speed, dangerous or reckless or negligent driving, including failure to stop at Compulsory Stops;

- Up to 500 points on each occasion, or exclusion for serious offence.

**20.2** Inconsiderate driving and/or misbehaviour entering or leaving Checks, Controls;

- First Offence: 50 points
- Second Offence: 500 points
- Third Offence: Exclusion.

- 20.3** Exceeding the legal speed limit in a Speed Trap;
- 15 points per kilometre per hour or part thereof in excess of the legal speed limit.
- 20.4** Consumption of intoxicating liquor or illegal non-prescription and banned drugs during the Navigation Rally;
- Immediate exclusion.
- 20.5** Incorrect lighting;
- 50 points.
- 20.6** The use of radio transmitting and receiving apparatus, (eg: cellphone, for the purpose of obtaining private assistance);
- Exclusion.
- 20.7** Failure to comply with officials' or marshals' instructions – pertaining to the conduct of the Navigation Rally or failure to obey Navigation Rally rules;
- 50 points on each occasion.
- 20.8** Failure to report on time for vehicle scrutineering and/or competitors' documentation;
- 25 points.
- 20.9** Failure to report on time for departure from Start Point;
- 25 points on each occasion.
- 20.10** Arrival at the Start line without competition numbers, if required (and/or any other notices/decals required by the SR), mounted on the vehicle, in accordance with the Regulations;
- 20 points.
- 20.11** Late or early arrival at checks or controls where time is recorded. In excess of thirty(30) seconds late or early;
- One tenth of a point per second to a maximum of 180 points.
- 20.12** Failure to pass or stop at a manned Check or Control at which time is recorded, and/or failure to pass or record time at an unmanned Time Check.;
- 180 points.
- 20.13** Stopping, reversing, deliberate deviation from or turning on the official route, so as to delay arrival and/or change approach, executed within sight of a manned Check and/or Control (Marshals or Officials must actually see the infringement occur);



- 150 points on each occasion.
- 20.14** Failure of competitor's sealed timepiece for each manned Check or Control subsequent to such failure until and including the next manned Check or Control where the timepiece can be reset and re-sealed;
- 180 points on each occasion.
- 20.15** Maximum aggregate points lost at any one(1) manned Check or Control, or unmanned Time Check as listed under headings 20.11-20.14;
- 180 points.
- 20.16** Failing to report within thirty(30) seconds of stopping past a manned Check or Control, except in Touring Section/sub-section;
- 50 points.
- 20.17** Failure to pass and note down the check code at an unmanned Check and/or failure to pass or stop at a manned Check or Control which does not record time;
- 60 points.
- 20.18** Failure to give proper turning and/or stopping signals;
- 25 points.
- 20.19** Incorrect parking (A stationary car for the purpose of these regulations is deemed to be parked);
- 10 points.
- 20.20** Unauthorised opening of CRI;
- 300 points per occasion plus maximum loss of points for each Check and Control throughout the section/s involved.
- 20.21** Falsifying entries on drivers' cards or tampering with timepieces or seals or failure to have alterations to recorded times signed by an official;
- 300 points up to exclusion.
- 20.22** Imposition of any penalties specified in these Regulations and/or SR for a competition shall not prevent the imposition of such other penalties as may be specified in the National Sporting Code.
- 20.23** By notification in the SR for club Navigation Rallies some of the above penalties may be reduced, but this must be done in a proportional manner. (e.g. Timing and check penalties may be divided by six(6) thus giving a points loss of one(1) per minute and ten(10) points per check missed).

## Part Four – Diagrams

The diagrams referred to in the rules.

D1

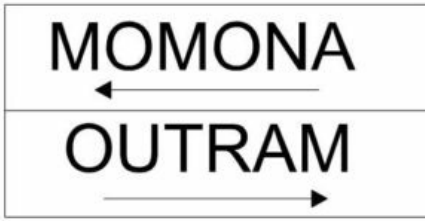

D2



D3

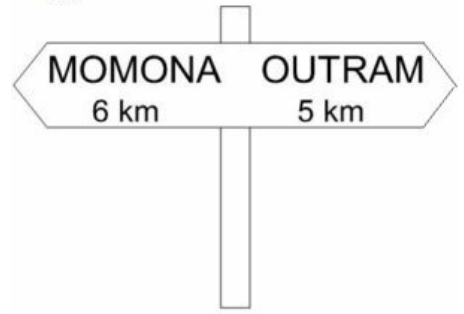

D4

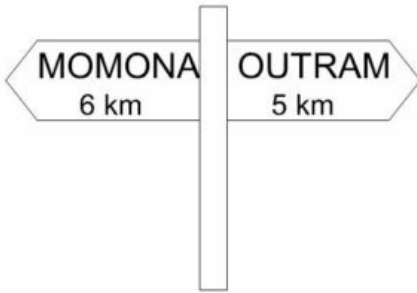

D5



D6

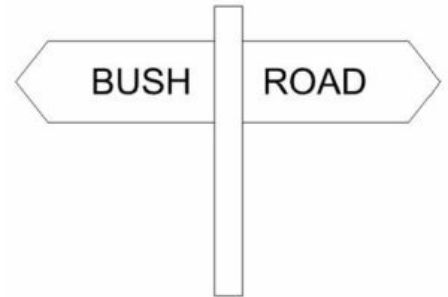

D7

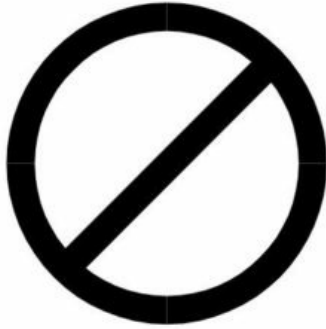

D8



D9



D10



D11



D12



D13

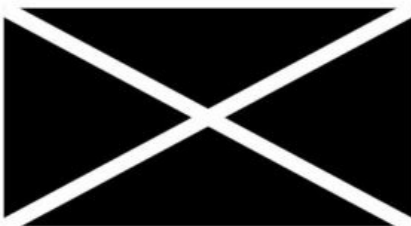

D14



D15



D16

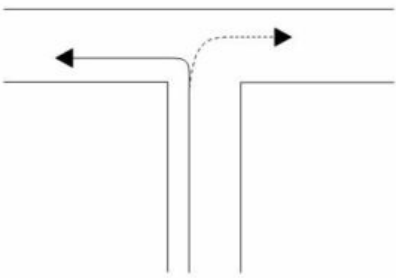

D17

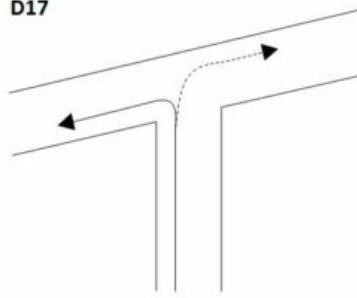

D18

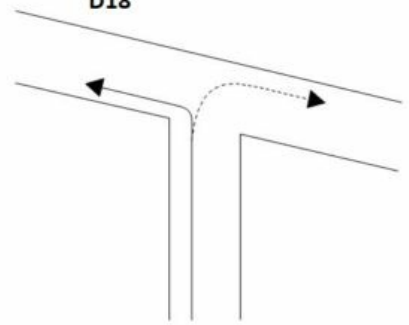

D19

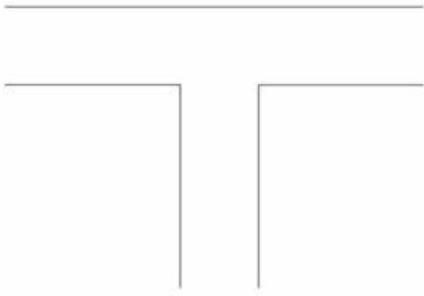

D20

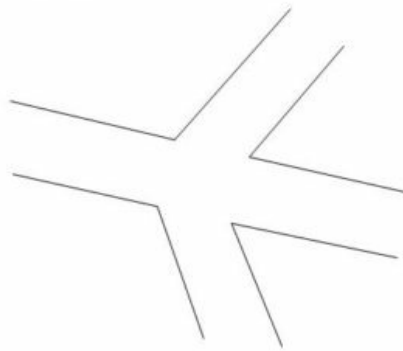

D21

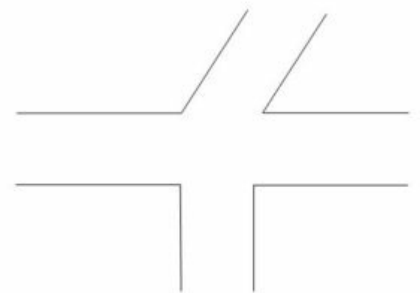

D22

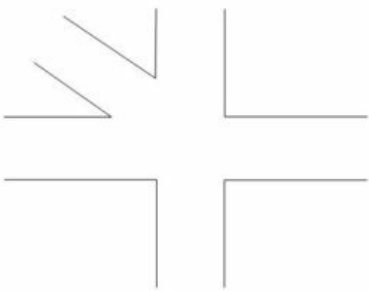

D23

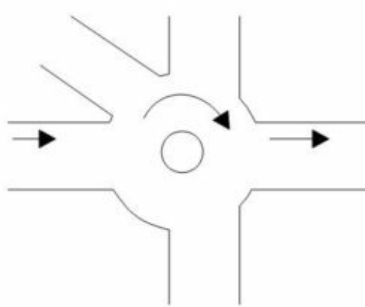

D24

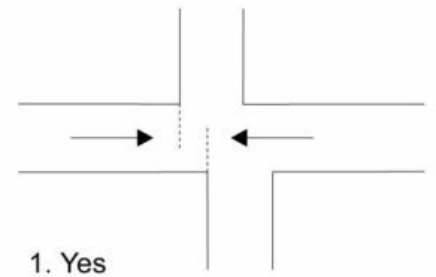

D25

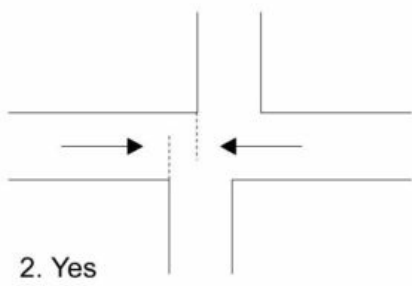

D26

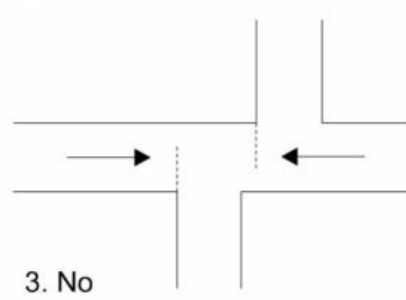

D27

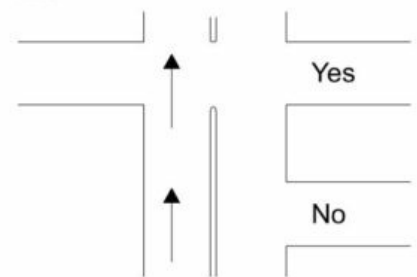

D28

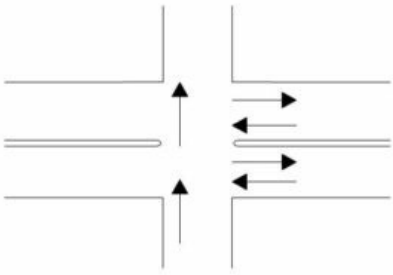

D29

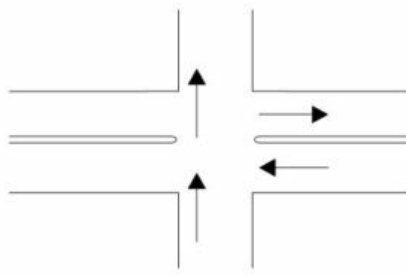

D30

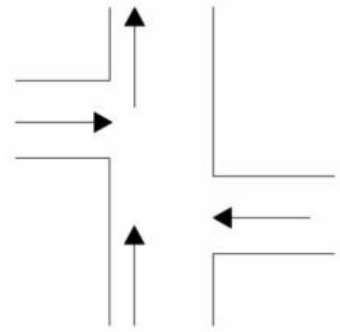

D31

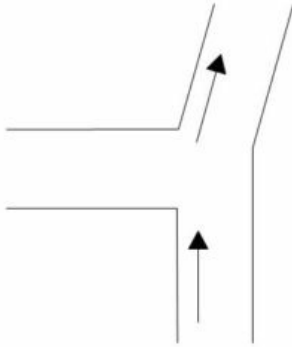

D32

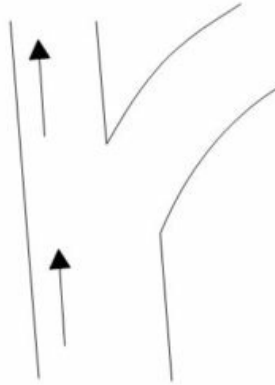

D33

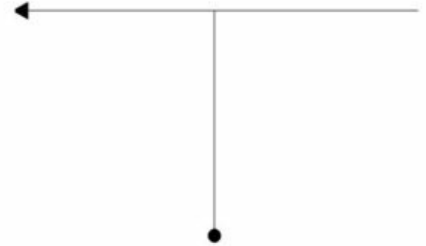

D34

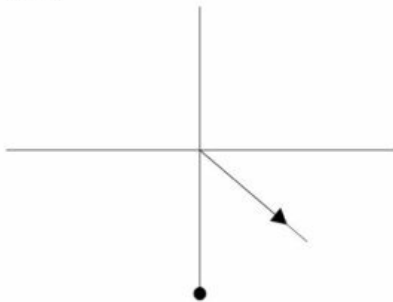

D35

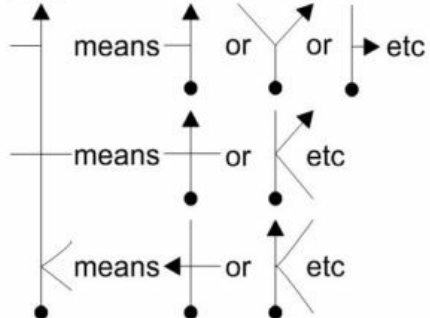

D36

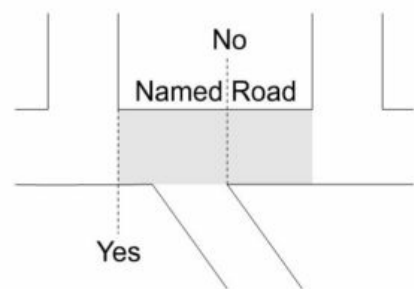

D37

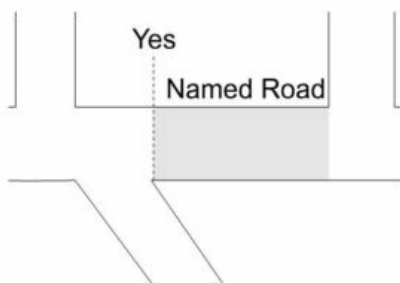

D38



D39

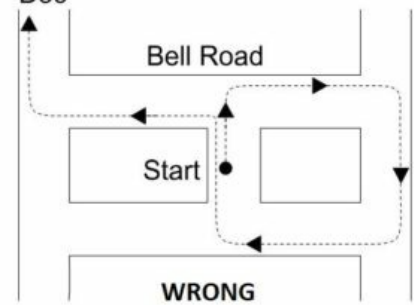

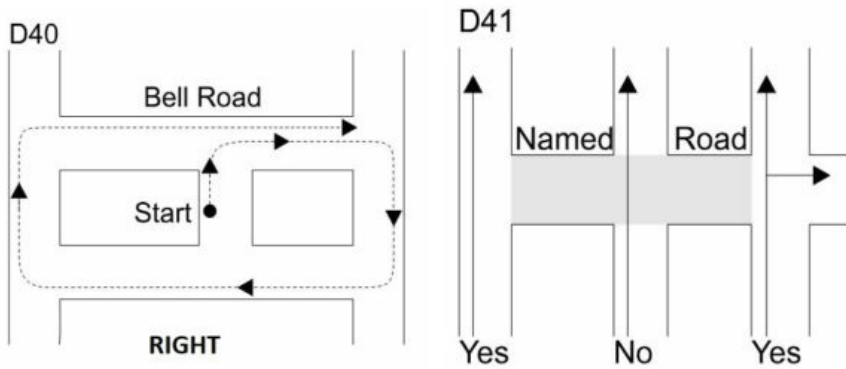

## Part Five – Helpful Hints

This part is NOT part of the rules or regulations but has been prepared to assist new competitors to gain some knowledge of what to expect when competing in a Navigation Rally.

### Participants in a Navigational Rally

The participants of a Navigation Rally are collectively referred to as The Crew. The crew is made up of a minimum of two(2), being the Driver and a Navigator. Additional crew members up to the maximum seating limit of your car are permitted. The Crew are:

**The Entrant:** The person noted on the entry form as the Entrant. This person can be any member of the crew.

**The Driver:** The person who drives and must hold a NZ civil drivers licence which is current and full (not restricted).

**The Navigator:** The passenger who reads (out loud) the Supplementary Regulations (SR's) and Competitors Running Instructions (CRI's), or reads the maps, and tells the driver where to go.

**The Co-Driver (optional):** The person who is often passenger but may drive occasionally and must hold a valid NZ civil drivers licence as per the Driver.

**The Timekeeper (optional):** The passenger who calculates the time, based on distance travelled, to adhere to the speeds set in the CRI's. Any of the above drivers or navigator can also assume this role.

**The Passengers (optional):** Any additional persons not taking any role above. These persons are often not Club members or are newcomers or not regulars within the crew. Additional crew members are helpful in spotting Check Boards and the purposeful mistakes (Traps) in the CRI's and SR's.

### Organisers of a Navigational Rally

**The Organiser:** (also known as the Promoter). The person or team of people who plot the Navigation Rally in the geographic area they have chosen and construct the Supplementary Regulations (SR's), Part 2 and the CRI's. They arrange printing of these and driver's cards for use on the event and also the Check Boards and other signs that are required. This is often a crew that normally competes but takes a turn in organising an event on the Club's calendar.

**The Secretary:** The person who arranges the Permit application and the SR's (Part 1) which is the advertisement or notice of the event that is sent to potential competitors / participants.

**The Clerk of the Course:** Usually this is the main organiser. However there may be another Clerk of the Course appointed.

**The Checkers:** The person(s) who accompany the Organisers on the "Checking Run" to ensure that there are no errors or contentious instructions that will cause confusion and create argument that can make an event less enjoyable.

### Preparation for a club event

- You require a motor vehicle with a working speedometer and odometer, a driver, a navigator, a clipboard and pen and a clock or watch. You may also take a timekeeper and passengers.
- You can usually compete in your first one or two Navigation Rallies without having to join a car club. No motorsport licence is required except at MotorSport NZ Championship events, but the driver does of course require a drivers licence.
- Find out the level of event you intend to compete in.
- If it is a 'fun' event the only other thing you probably need is a sense of humour. Nevertheless study any rules issued for the

event.

- If it is a 'timekeeping' Navigation Rally then you need to know what Navigation Rally terminology is used to describe roads and intersections and how to do some basic timekeeping. Study only those sections of the rules.
- If it is a 'novice' Navigation Rally find out which sections of the rules will be used and study only those sections.
- If it is your first event be sure to turn up on time for documentation, and ask the organiser if there is an experienced competitor who can assist you with information on the requirements for the event. Look at the sample CHECK boards and any other signs which the organiser has on display in order to be familiar with what you should be looking for during the event.
- Fill in and sign the entry and pay any entry fee.

**Supplementary Regulations (SR):** (*Refer Article 4.6*). These should be given to you as soon as you arrive. Study the SR and underline or highlight the information which will be of navigational importance. (There is often much information which only pertains to the details of the running of the event).

Therefore study:

- (1) How signs will be quoted in the documentation.
- (2) The order of priorities where more than one(1) instruction is possible at any one time.
- (3) Action to be taken when encountering certain check codes.
- (4) Any overriding instructions, and which sections they apply to.
- (5) What abbreviations will be used on this event.
- (6) Any other details pertaining to the running of the event.

**Competitors Running Instructions (CRI):** (*Refer Article 4.10*). These will be given to you about two(2) minutes before you start. They are the basic instructions which advise how to negotiate most intersections. BUT remember to apply other instructions listed in the order of priorities as applicable. eg overriding instructions in the SR, or overriding instructions listed at the top of the CRI, or instructions to be carried out at some check boards.

- Tick each instruction as it is completed
- Cross out those that are deleted.
- These will also contain the average speed required and where changes to the average speed apply.

**Odo Distance:** (*Refer Article 11*). Do not forget to zero (or note) your odo at the start point.

**Local Knowledge:** Always follow the instructions for the event, do not use local knowledge (unless you are lost and need to get back to a known point in the event). For example you have a CRI which states "Go right into main road". You may know which road is THE main road in your area but in this case you cannot assume that your 'main road' is the correct one. You will need some additional information such as a sign "MAIN ROAD".

Remember, if you think you are lost read ahead in the instructions and try to identify an instruction which you can find. eg Go right at "BELLS ROAD". Go to that point and continue with the Navigation Rally.

**Straight Ahead Rule:** Normally the lowest order of priority for instructions is 'The straight ahead rule'. This means proceed ahead on the road of least deviation, even though this may mean leaving a major road you are on and continuing into a minor road or even a track!

- CRI by distance – refer Article 12
- Tulip diagrams – refer Article 15
- Straight line maps – refer Article 16
- Touring section – refer Article 14.7
- Overriding instruction – refer Article 4.8

- Manned check handout – refer Article 4.9

The above rules are short and concise, therefore make sure you take this booklet with you whenever you compete in a Navigation Rally to study whenever you are confronted by one of the above variations of instruction.

**Common Route and 'Traps':** (*Refer Article 13*). You will normally miss an unmanned check if you do not recognise a 'trap'. This is where the organiser, on purpose, does not obey the rules. Examples are:-

- Traps on signs, where the actual sign and the instruction differ in some way, (*eg. Refer Article 8 for rules governing signs*).

(Assuming SR states signs will be quoted in capitals)

Sign reads:	Instruction reads:	Trap is:
GIVE WAY	GIVE WAY	instruction misspelt
JOHN RD	JOHN ROAD	sign not quoted correctly
PICTON 5 KM	PICTON ___	sign not quoted in full
VALLEY ROAD	VALLLEY ROAD	instruction misspelt
McLEAN Rd	McLEAN Rd	not valid if SR states signs will be quoted in capitals, (however MCLEAN RD would be correct).
and many, many more possibilities		

- When you encounter a 'trap' check the Order Of Priorities list in the SR and use the appropriate instruction to negotiate the intersection where the 'trap' is, usually the straight ahead rule, to find a check code which will put you on the 'common route'.
- Normally on a well organised Navigation Rally you will not know that you have missed a 'trap' until you get the explanation sheet at the finish. The organiser should ensure that competitors who miss the 'trap' will rejoin the common route without getting lost.
- It is a rule that organisers must put checks where time is recorded on the 'common route'. (*Refer Article 6.6*)

**Map Reading:** (*refer Article 17*). The supplementary regulations AND any pre event publicity must advise if map reading is going to be used on a Navigation Rally because you will need to buy the appropriate map. You will then (and only then) need to study Article 17.

### Taking Part in a Navigation Rally

**Prior to the start:** The Organiser will have sent out the Supplementary Regulations (Part 1) which gives details of the event, start location and other pertinent information. Some Clubs may not use SR (Part 1's) as this information may be contained in monthly newsletters or bulletins.

**Arriving:** A crew arrives at Start Control at the location outlined in the Supplementary Regulations (Part 1) and are given the Supplementary Regulations (Part 2) (these are the basic pieces of information which apply to the event), an entry form and a drivers card on which they must write all of the "Check Codes" (a Check Code is the letter or group of letters on the top of a CHECK board) on each CHECK board they see.

They set their clock to their car number in minutes behind the official clock as outlined in the SR's.

They should collectively read through the SR's and discuss anything outside the normal, such as any over-riding instruction. Ask the Clerk of the Course or Organiser for clarification if needed.

**Starting:** Two(2) minutes prior to the start time, hand in your entry form and entry fee (if not already done) and collect the CRI's (Competitor Running Instructions) and get your car and crew to the START board ready to leave at the official start time.

Check the CRI's to see if there is an over-riding instruction or anything unusual.

Zero the trip meter in the car.

**Competing:** The Navigator clearly reads each instruction to the Driver who follows the instruction at the Average Speed stated in the CRI's (or the separate Speed Schedule if there is one).

EACH INSTRUCTION MUST BE COMPLETED OR DELETED BEFORE THE NEXT IS ATTEMPTED.

Usually the first board sighted will be the ODO board stating the distance the organiser travelled from the Start to this point so competitors can compare their own trip meter with this distance and adjust their timing if there is a variation in the distance.

The Driver is responsible for driving within the law and keeping to the average speed (usually travelling at 20kph above the average speed to allow for the stops and turns). The Driver also spells out the road signs to compare with any quoted sign in the CRI's. The Driver must also find the CHECK boards.

The Time keeper keeps track of the kilometres travelled and calculates the time the Rally should be taking based on the average speed. He will tell the driver to speed up or slow down.

**Traps:** These are purposeful errors made by the Organisers to determine the winners. A trap may be a spelling error or using an instruction that is impossible to complete. There are many variations of these so it is helpful to be familiar with the other areas of this Schedule.

Missing a trap means missing a CHECK board worth 60 points!

**Check Boards:** Write them all down – they all count but must be in the correct order.

**Manned Time Checks:** Take your Drivers Card and clock to the person in the vehicle with a CHECK sign on the back of it. Park in front of this vehicle to avoid blocking the CHECK sign from being seen by other competitors.

**The Objective:** To reach the finish in exactly the same time as the organiser calculated and see all the CHECK boards and write them down on the Drivers Card in the correct order. Doing so will avoid penalty points and to score zero(0) is the ultimate achievement and will earn first place.

**The Finish:** The final instruction will ask the competitors to take their Drivers Card and clock to the final CONTROL. This is the time to relax and review the event. A list of CHECKS and the speed schedule will be available.